

Arduino Duemilanove

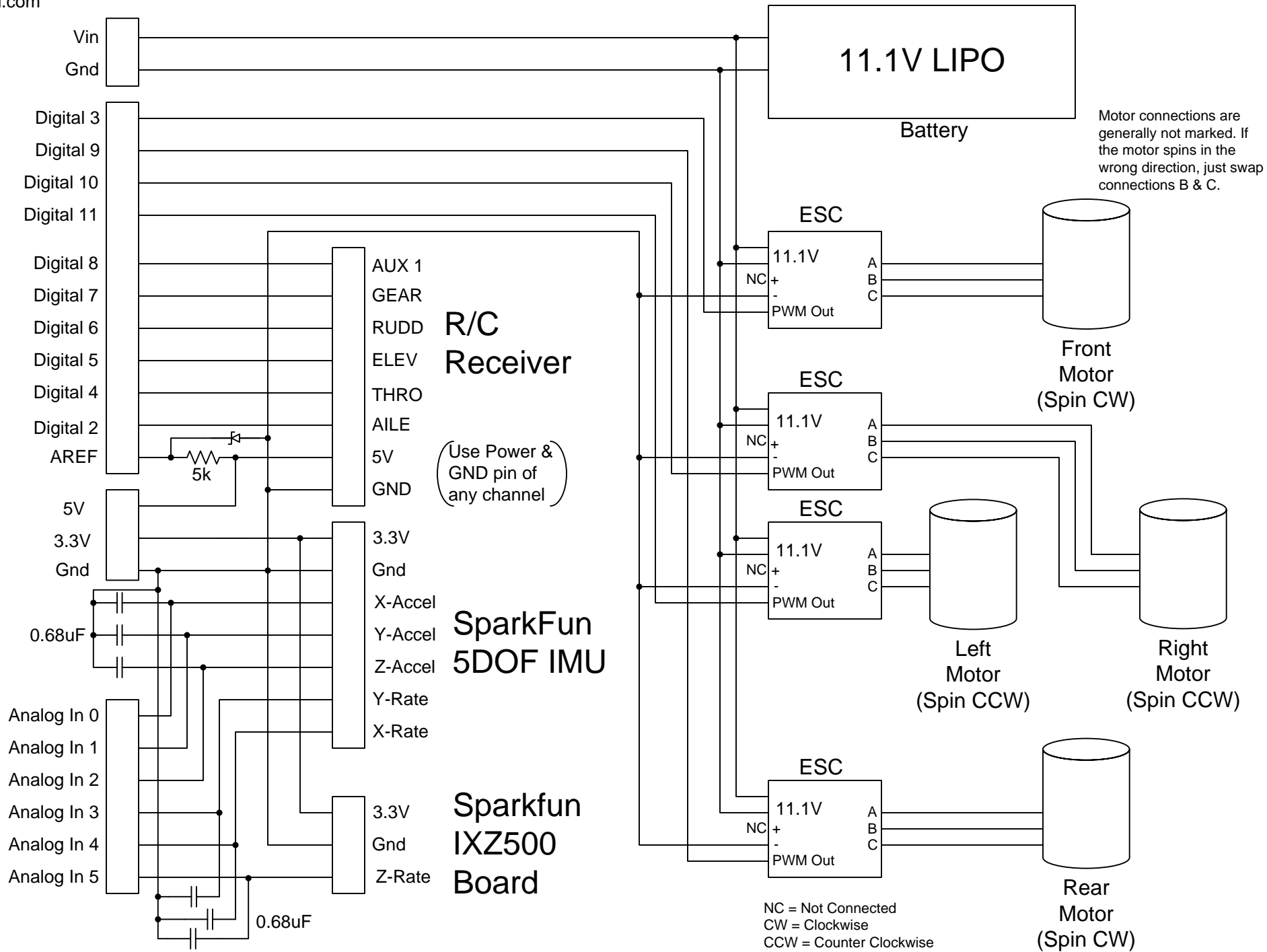

Motor connections are generally not marked. If the motor spins in the wrong direction, just swap connections B & C.

(Use Power & GND pin of any channel)

NC = Not Connected
 CW = Clockwise
 CCW = Counter Clockwise

Note:
 This interconnect diagram works with the AeroQuad v1.7 software which can be downloaded from <http://AeroQuad.com>. Channels can be reassigned by modifying the pin out definitions in the software.